

UG-599

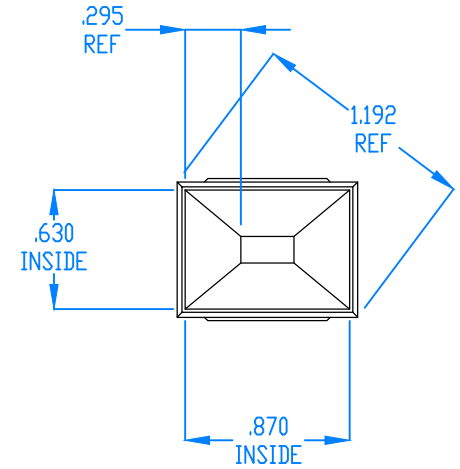
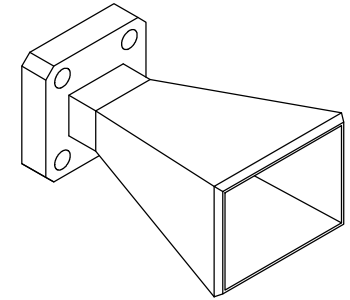
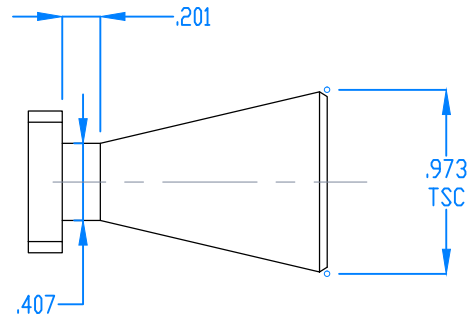
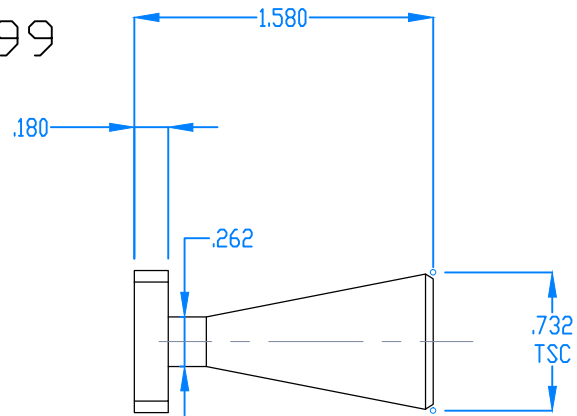

| | | | | | |
|---|----------------------|----|----------|--|---------------------|
| DECIMALS: XXXX ±.0005 XXX ±.005 XX ±.01 ANGLES: ±.5 DEGREESS | DRAWN | JV | 11-20-14 | TITLE: Mi-Wave Millimeter Products Inc. SIZE DWG. NO. 261A-15-599 OUTLINE 22651 SCALE: 1:1 | REV SHEET 1 OF 1 |
| | CHECKED | MS | 11-20-14 | | |
| | ENG | MS | 11-20-14 | | |
| THIRD ANGLE PROJECTION | MATL: 1/2 HARD BRASS | | | WEIGHT: | |